



Pre-Fire Planning Guide for Resource Managers and Landowners in Hawai'i and Pacific Islands

Clay Trauernicht¹ and Elizabeth Pickett²

¹University of Hawai'i Cooperative Extension Service, ²Hawaii Wildfire Management Organization

**“An ounce of prevention is worth a pound of cure.”
– Benjamin Franklin**

Wildfires are prevalent in dry areas of Hawai'i and many regions of the US-affiliated Pacific Islands. In Hawai'i, the area burned annually by wildfire has increased more than fourfold in recent decades, and wildfires are frequent during the annual dry seasons in the savannas of the western Pacific islands including Guam, the Northern Marianas, Yap, and Palau. This guide is intended primarily for natural resource managers and landowners who are responsible for larger tracts of land and concerned about wildfire risk. It outlines the primary drivers of fire occurrence in the region—namely, abundant fine fuels like grasses; frequent, human-caused ignitions; and dry conditions brought on by seasonal drought and rain shadow effects—as a brief introduction to wildfire risk assessment. The information presented here is primarily intended to assist in preparedness planning that will increase the safety of people, infrastructure, and other valued resources and improve the effectiveness of suppression efforts by professional fire responders in the event of a wildfire incident.

As the landowner or manager, your local knowledge of resources like water, road access, and high priority landscape features (crops, endangered species) is critical to minimizing the impacts caused directly by the wildfire as well as the impacts caused by fire suppression operations. Good pre-fire plans identify valued resources, fire hazards, access, and water resources for responders and provide operational and evacuation

procedures for land managers. This guide addresses how to compile and present the information in a pre-fire plan and lists people with whom plans should be shared. It also provides a checklist of features that should be included in a good fire plan. Not all items on the checklist will apply to all situations. You as the land manager must decide which are relevant. Compiling this information is also a critical first step to identify ways that wildfire risk can be reduced through actions such as fuel breaks and fuel reductions, road widening, and increasing or improving water access.

It is strongly encouraged that managers contact and meet with fire response professionals (in Hawai'i, these are typically the County Fire Departments) to discuss their plans and identify areas for improvement. Onsite consultations are ideal to familiarize responders with the land and ensure the best outcomes. Developing these relationships will help you better understand the challenges of wildfire response in your area and will help responders better understand your resource priorities and wildfire risk exposure.

Assessing the Fire Environment

Wildfire occurrence depends on three basic factors: ignition sources, the right climate and weather conditions, and vegetation (i.e., fuels).

Ignition: Natural ignition sources in Hawai'i include active lava flows and lightning, but nearly all wildfires in Hawai'i are from human-caused ignitions such as cigarettes; campfires; and sparks from machinery, welding, and catalytic converters on cars. During times

of increased fire risk (see Climate and Weather below), land managers should consider steps they can take to control the activities occurring on the land in order to limit exposure to human-caused ignitions.

Climate and Weather: Climate and weather conditions that increase fire risk include prolonged drought and periods of high temperatures, low humidity, and high winds. Hot and dry conditions allow fuels to “cure,” while high winds increase the danger of fire spreading rapidly across the landscape. Climate and weather are therefore important to monitor and can inform managers about when to reduce ignition risk or take proactive steps to reduce fuels. See Resources section below for relevant fire weather websites.

Fuel: Vegetation provides fuel for wildfires to burn. Fine fuels like grasses dry out, or cure, rapidly and ignite easily, whereas woody plants require drier conditions and more energy (i.e., hotter fires) to ignite and burn. The presence of continuous fuels both horizontally across the land and vertically from the ground into tree canopies is a good indicator of how fire might spread. Large expanses of grasses provide surface fuels that carry fire quickly over large areas, whereas dense shrubs and dead branches can provide ladder fuels that allow fire to spread up into tree canopies (Figure 1). Identifying hazardous fuels is the first step in developing fuels-reduction plans to reduce fire risk, including

thinning ladder fuels beneath tree canopies and establishing fuel breaks—strips where vegetation is reduced or cleared. A discussion of these strategies is beyond the scope of this guide, but it is recommended that you consult with local resources (UH Cooperative Extension Service or the Hawaii Wildfire Management Organization) for guidance on implementing fuels reductions.

Fire Behavior: Assessing the fire environment also requires an understanding of how weather, fuels, and topography drive fire behavior (Figure 2). As described above, fuels or vegetation type and continuity are important in determining the potential for fire to spread. But wind direction and strength may be the most important—and most unpredictable—factors driving the direction and speed that fires move across the landscape. Fires move more rapidly uphill than downhill, and drier, south-facing slopes often pose a higher fire risk than moister, north-facing areas.

Factoring weather, topography, and fuels become especially important when managing vegetation to reduce fire risk. Fuel breaks are much more effective, for example, when placed perpendicular to the prevailing wind direction and in areas where the fire approaches the break moving downslope. Remember fuels-management strategies are not intended to stop fires, but to slow fire spread and provide fire responders areas from which to defend valued resources.



Figure 1. Illustration of surface fuels, such as grasses, that carry fires horizontally across the land and ladder fuels that allow fires to “jump” up and burn tree canopies.



Figure 2. Once a fire is ignited, weather, topography, and fuel availability are the factors that determine the direction and speed at which it moves across the landscape.

What Should Your Plan Look Like?

Maps are one of the most effective ways of organizing and communicating the information contained in a pre-fire plan to fire responders. Valued resources, evacuation routes, structures, hazards, water sources, roads, gates, and access points can be easily identified on maps using different symbols and a corresponding legend (Figure 3). Depending upon the size and complexity of the lands you manage, this may require a series of maps. Additional information can be provided as a supplement to the maps, such as checklists with contacts of residents and leaseholders, lock combinations for gates, and evacuation procedures to follow in the event of a fire.

Given Hawai'i's complex topography, some managers have used Google Earth (www.google.com/earth/) to provide 3-dimensional perspectives of the whole watershed, which can greatly assist fire response agencies in locating valued resources (Figure 4). This can be especially useful when conditions and access require helicopter operations. The main point to keep in mind is to present the information as clearly as possible

so that both you, as the land manager, and the Incident Commander in charge of fire suppression can easily access and understand the information provided.

Communicating About Your Pre-Fire Plan

For land management units involving multiple leaseholds or on-site residents, all interested parties should be familiar with the plan and ideally contribute to its development. It is also strongly encouraged that landowners and managers review their pre-fire plans with local fire suppression agencies. This is to ensure that the relevant information is understandable and to familiarize agencies with the lands you manage. County Fire Departments are typically the first agency to respond to fires in Hawai'i. Where lands are adjacent to government lands, it may be useful to contact the state fire responders with the Hawai'i Division of Forestry and Wildlife or federal agencies such as the National Parks and Wildlife Refuges or military installations. Wildfire response jurisdiction maps are available through the Hawaii Department of Land and Natural Resources (see Resources section below).

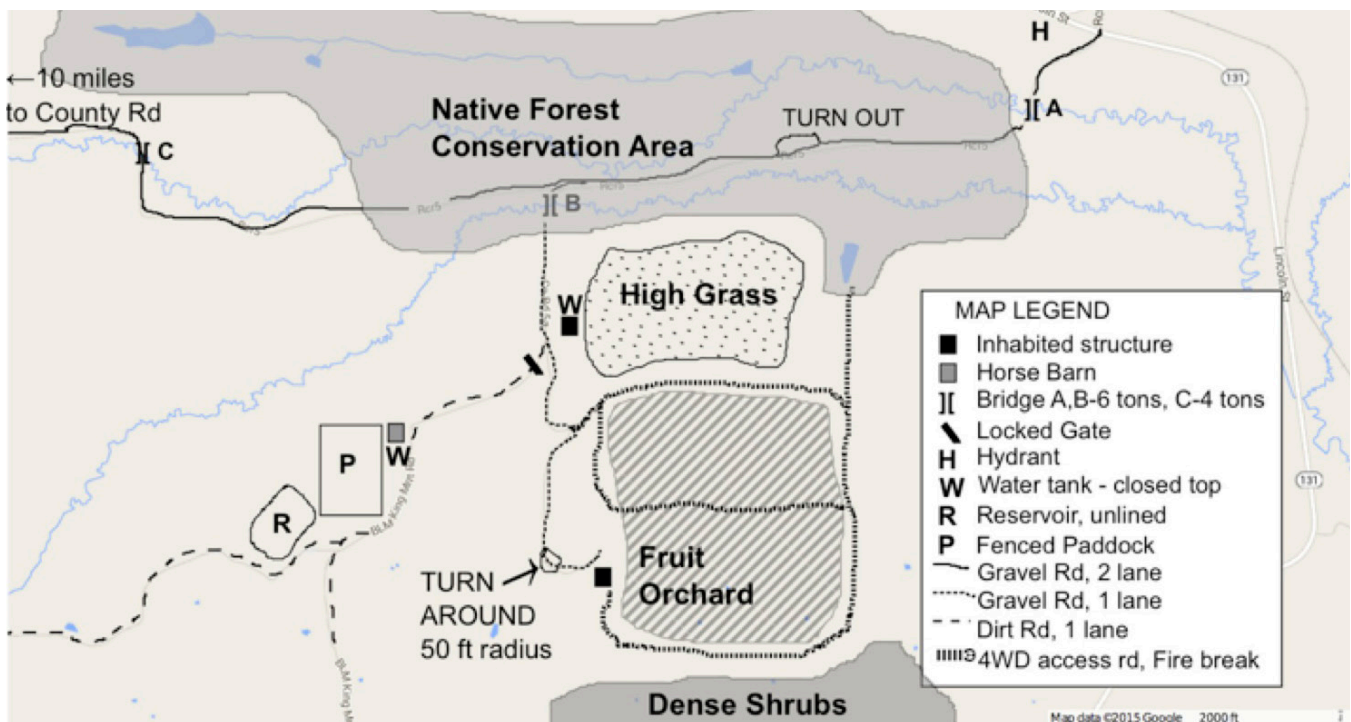

Figure 3. Depending on tenure and the size and complexity of the management unit, fire plans can range from simple resource maps like this one to plans containing multiple maps, evacuation procedures, and contact lists.

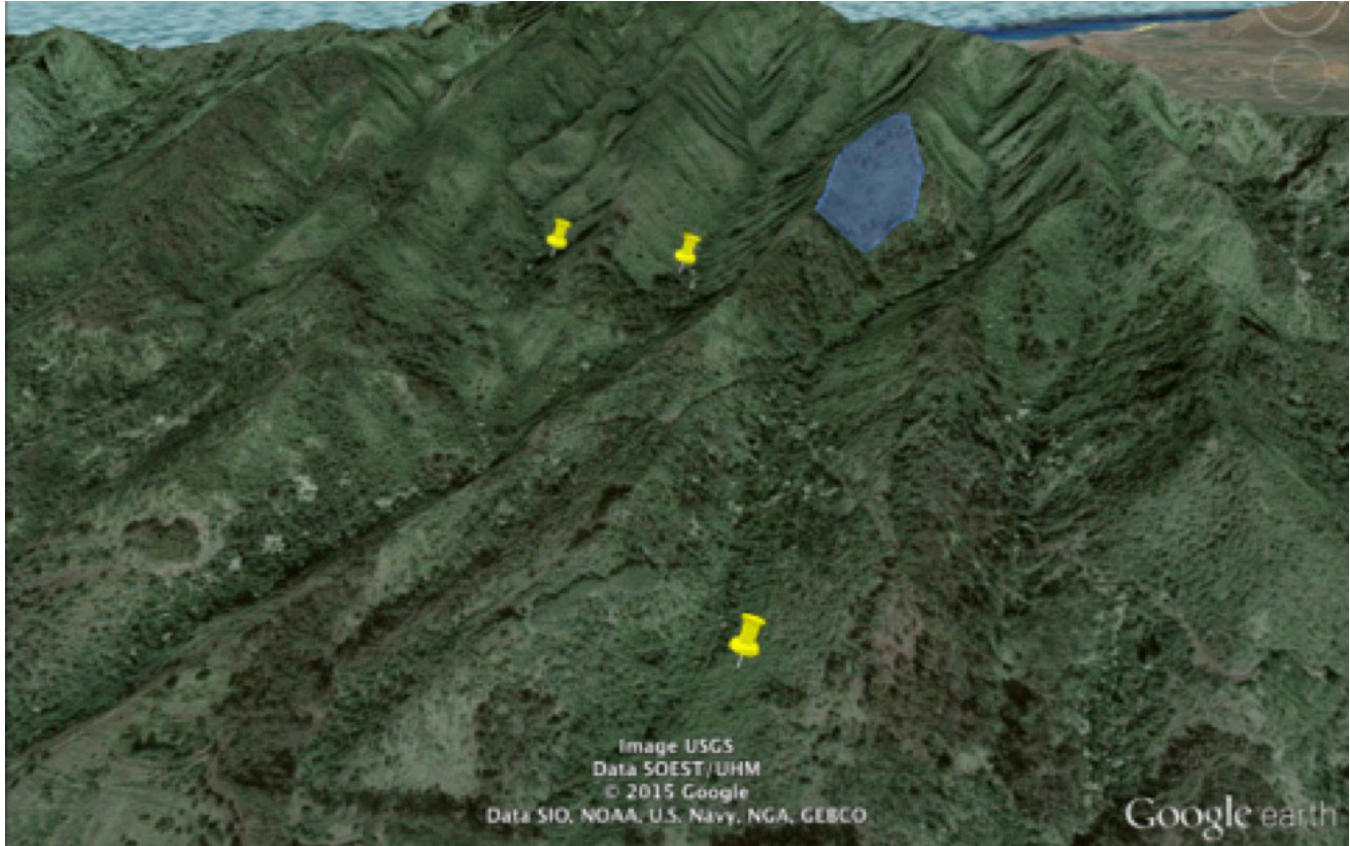

Figure 4. Google Earth is a free and useful tool to create 3-dimensional maps that can help fire responders locate valued resources in complex terrain and large landscapes. Users can add placemarks (yellow pins) to indicate single locations or draw “polygons” (blue area) to indicate larger, high-value areas.

Factors to Consider for Pre-Fire Planning

Prioritizing Resources: Assets on the land can be ranked according to their value and exposure to wild-fire risk and/or damage from suppression efforts (i.e., high value/high risk to low value/low risk). Human life and inhabited structures always rank highest, followed by, for example, high-value natural resources, cultural/historical sites, and uninhabited structures.

People: Human safety is always highest priority. Develop an escape plan including evacuation routes and safety zones and ensure that all residents and employees are familiar with the plan. Safety zones are areas without burnable fuels where all people can survive the passage of a wildfire. Technical guidelines exist for the establishment of safety zones. If you are interested in determining whether existing areas meet

these guideline or establishing new areas as safety zones, please contact the CTAHR Wildland Fire Extension Program.

Livestock and Pets: Pre-arrange escape and transportation plans and alternative safe areas for livestock and pets. Hazards to consider are whether corrals and fencing might prevent or complicate escape as well as flammable bedding materials.

Infrastructure: Inhabited structures are also considered high-value resources. Locations of uninhabited buildings and other structures like communication towers and powerlines are also important to indicate in your plan. Identifying the presence of explosive and/or hazardous chemicals (e.g., propane tanks) is extremely important for safety.

Vegetation: Plans can indicate areas of hazardous fuels such as continuous high grasses or dense, woody vegetation that may act as ladder fuels. Similarly, “weak points” along roads and firebreaks such as narrow areas or taller vegetation can also be helpful for fire responders. Hazardous fuels such as high grasses and/or dense vegetation should be cut back to a minimum of 30 ft around structures to provide defensible space.

Communication: County Fire Departments (dial 911) are typically first to respond to wildfires in Hawai‘i, but wildfires on or adjacent to state lands may also involve the Hawai‘i Division of Forestry and Wildlife. Including contact information of residents and neighboring landowners and establishing phone or text chains can ensure that people are alerted during a fire. For large and/or remote land holdings, maps of cellular and radio coverage can greatly assist fire responders to maintain communication during suppression efforts.

Water Availability: Fire hydrants, water tanks, reservoirs, and even ditches and streams should be indicated on maps. Also indicate whether they are easily identifiable and accessible by vehicles. Check the size and type of outlets on water tanks and consult with fire response agencies to ensure fittings are compatible. The use of linings or anti-fouling chemicals in reservoirs may prevent their use by fire suppression agencies. Improving water access can greatly improve wildfire response. It is important to check the accessibility and availability of these resources at least twice a year.

Access: Safe entrances and exits are critical for human safety and effective fire response. The location and width of locked gates, road conditions (4WD required or seasonal access), road width (single or double lane), turn-outs where vehicles can pass one another, turn-arounds for fire engines (Figure 5), and bridges with weight limitations should all be indicated on maps. In addition, the location of safety zones and/or potential staging areas to establish Incident Command operations can be useful for fire responders. Clearly marked road signs can also help response agencies locate the property.

Natural and Cultural Resources: Endangered species, critical habitat, agriculture, and archaeological sites and other cultural resources that landowners and

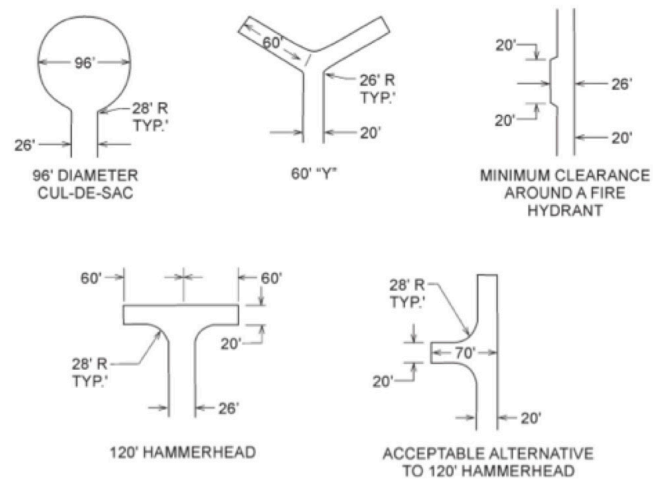

Figure 6. Recommended turn-arounds for fire engines (by Oregon State www.iccsafe.org/).

managers have prioritized should also be indicated on maps. Fire responders respect and understand these values and will work to protect them if possible. For large land areas and/or large fires, it may also be appropriate to designate a Resource Advisor to work with response agencies.

Additional Resources in the Community: Neighboring landowners may have access routes and resources such as reservoirs, water tankers, and bulldozers that can be used and/or mobilized to assist in fire suppression efforts. Fire response agencies may not be aware of these additional resources, so it is important to establish good relationships with surrounding community members and identify opportunities for assistance.

Sensitive Areas for Suppression Efforts: Landowners may be most concerned with the direct effects of the wildfire itself, but suppression efforts by fire response agencies can also have impacts. In addition to personnel and vehicles, helicopters and heavy equipment (e.g., bulldozers) are often brought onsite to drop water and cut lines through vegetation in order to contain the wildfire. Therefore it is very important to identify areas and assets (e.g., endangered species, crops, archaeological sites) that are sensitive to potential wildfire operations. Although wildland fire agencies (DOFAW) adhere to “Minimal Impact Suppression Techniques,”

these agencies will depend on you as the landowner or manager to identify and communicate the locations of these sensitive areas/assets. Similarly, you can also recommend locations where activities such as establishing a command base, setting up portable diptanks, running helicopter operations, and bulldozing access routes will have minimal impact.

Planning for Post-Fire Response: In planning for a wildfire event, it may also be useful to outline strategies for post-fire recovery. Putting out the fire is just the first step in managing wildfire impacts. Post-fire assessment and monitoring can help identify where wildfire effects have been the most severe to help prioritize areas for rehabilitation. For more information, refer to “Post-Fire Vegetation and Soil Monitoring in Hawai‘i” (see Resources below). Preparedness plans can also outline potential resources available and strategies for addressing post-fire impacts such as increased erosion, loss of vegetation cover, and incursion of weeds.

Conclusion

Fire suppression requires specialized knowledge, experience, and equipment, but local knowledge of resources and the landscape can improve the safety and effectiveness of wildfire response. It is your responsibility as the landowner or manager to prepare a pre-fire plan that can communicate this information to fire response agencies. Consider the features outlined above, compile the necessary and relevant information, and organize this information in a way that is clear and understandable. If there are any questions, help is available through the University of Hawai‘i Cooperative Extension Service, the Hawaii Wildfire Management Organization, and/or your local County Fire Department.

Acknowledgments

Thanks to Susie Kocher of University of California Cooperative Extension Service, Kawika Smith of the Hawai‘i Division of Forestry and Wildlife, Willie Rice of Forest Solutions, and JB Friday of the University of Hawai‘i Cooperative Extension Service for feedback and input on this guide.

Resources and References

Protecting Tree Plantations from Fire in Hawai‘i (<http://www.ctahr.hawaii.edu/oc/freepubs/pdf/RM-18.pdf>)

Hawaii Drought Monitor: www.HawaiiDrought.com

National Weather Service Fire Weather Products:

Hawai‘i: <http://www.prh.noaa.gov/hnl/pages/firewx.php>

Guam: <http://www.prh.noaa.gov/guam/fireWeather.php>

Hawaii Fire Jurisdiction maps: www.dlnr.hawaii.gov/forestry/fire/response-maps/

Google Earth tutorial: <https://www.google.com/earth/outreach/tutorials/annotate.html>

National Wildfire Coordinating Group, “Resource Advisor’s Guide for Wildland Fire”: <http://www.nwcg.gov/publications/resource-advisors-guide-for-wildland-fire>

Post-Fire Vegetation and Soil Monitoring in Hawai‘i: <http://www.pacificfireexchange.org/research-publications/category/post-fire-vegetation-and-soil-monitoring-in-hawaii>

Sample pre-fire plan: <http://www.tncfiremanual.org/MoabWildfireResponsePlan.pdf>

APPENDIX: Pre-Fire Plan Template

Organize the information relevant to the site in both narrative form and, when possible, on maps.

- **Site Location**
- **Site Access/Directions:** Identify and describe all entry/exit points
- **Site Description:** Land area, topography, vegetation types
- **Fire-Sensitive Resources and Property Assets:** Locations and details of livestock, homes, infrastructure, natural resources, etc.]
- **Procedure:** Narrative of the process to be followed in the event of a wildfire, including notification, evacuation, and suppression actions, as follows:
 - Notification
 - *Fire response agency or agencies responsible for suppression in the area, with phone numbers*
 - *Emergency contacts:* list of staff, landowners, residents to be contacted in case of wildfire, with phone numbers
 - *Media response plan:* specific staff designated to interact with media, basic framework for response/communications with media, site fact sheet to be shared with media contacts
 - Evacuation Plan: escape route and protocol
 - Suppression Action
 - *Sensitive areas to be avoided by suppression vehicles and efforts:* archaeological sites, threatened and endangered species, etc.
 - *Known hazards:* dense vegetation, flammable materials, hazardous materials storage, power/gas lines
 - *Access limitations or hazards:* wet, low-lying, narrow, steep, or rutted areas where response vehicles may be hindered
 - *Safety zones/firebreaks:* potential staging areas and existing mitigation efforts
 - *Water resources:* reservoirs, hydrants, water tanks and fittings
 - *Communication:* cellular reception issues and/or radio “dead zones” if known, radio frequencies of responding agencies
 - *Other resources and contacts:* nearby water sources, access from neighboring lands, private resources/equipment on property which may be available to firefighters, with contact info
 - *Information concerning any cooperative agreements with multiple landowners or agencies*